

**VAXserver 4000 Series Systems
VS30U Graphic Upgrade
Addendum**

Order Number EK-VS30U-AD.001

Digital Equipment Corporation

First edition, May 1991

The information in this document is subject to change without notice and should not be construed as a commitment by Digital Equipment Corporation. Digital Equipment Corporation assumes no responsibility for any errors that may appear in this document.

The software described in this document is furnished under a license and may be used or copied only in accordance with the terms of such license.

No responsibility is assumed for the use or reliability of software on equipment that is not supplied by Digital Equipment Corporation or its affiliated companies.

Restricted Rights: Use, duplication, or disclosure by the U. S. Government is subject to restrictions as set forth in subparagraph (c) (1) (ii) of the Rights in Technical Data and Computer Software clause at DFARS 252.227-7013.

Copyright © Digital Equipment Corporation 1991

All Rights Reserved.
Printed in U.S.A.

FCC NOTICE: The equipment described in this manual generates, uses, and may emit radio frequency energy. The equipment has been type tested and found to comply with the limits for a Class A computing device pursuant to Subpart J of Part 15 of FCC Rules, which are designed to provide reasonable protection against such radio frequency interference when operated in a commercial environment. Operation of this equipment in a residential area may cause interference, in which case the user at his own expense may be required to take measures to correct the interference.

The following are trademarks of Digital Equipment Corporation: Digital, Q-bus, VAXserver, and the DIGITAL logo.

This document was prepared and published by Educational Services Development and Publishing, Digital Equipment Corporation.

Contents

- About This Manual** v

- 1 VS30U Graphic Upgrade**
- 1.1 Planning the Upgrade 1
- 1.1.1 Software Backup and Operating System Shutdown 1
- 1.1.2 Guidelines for Module Placement 1
- 1.1.3 Recommended Module Order 2
- 1.1.4 Checking System Limitations 3
- 1.2 Installing the VCB02 Module Set 6
- 1.2.1 VAXserver 4000 Model 300 Firmware System Revision Verification 6
- 1.2.2 VAXserver 4000 Model 300 ROM System Replacement 6
- 1.3 Relocating Modules 9
- 1.4 Installing a VS30U Graphics Kit 13
- 1.4.1 Configuring the VCB02 Module Set 13
- 1.4.2 Installing Modules 15
- 1.5 Installing the Monitor, Keyboard, and Mouse 15

- Figures**
- 1-1 Bus Grant Continuity Path (BA430 Enclosure) 2
- 1-2 BA440 Configuration Worksheet 4
- 1-3 BA430 Configuration Worksheet 5
- 1-4 KA670 CPU Module - Component Side 8
- 1-5 Releasing Quarter-Turn Captive Screws 10
- 1-6 Removing a Module 11
- 1-7 EMI and EOS Clips 12
- 1-8 VCB02 Module Cabling 14
- 1-9 Connecting the Cables to the VR299 Monitor 16

iv Contents

Tables

1-1	ROM Kit Description	7
1-2	CSR Settings for the VCB02 (Switchpack E4)	13

About This Manual

This manual is an addendum to the *Microsystems Graphics Upgrade Installation Guide*. The addendum describes how to install the VS30U option into a VAXserver 4000 that has either a BA440 or BA430 enclosure.

To install the VS30U option, you will need to refer to the following documentation: the *Microsystems Graphic Upgrade Installation Guide* and the *BA430/BA440 Enclosure Maintenance Guide*.

If you have a VAXserver 4000 in a BA2xx enclosure, follow the upgrade procedures in Chapter 3 of the *Microsystems Graphics Upgrade Installation Guide*.

Organization

This addendum contains one chapter, VS30U Graphic Upgrade, which describes how to:

- Plan the upgrade.
- Remove and install modules with covers.
- Configure new modules.
- Perform ROM replacement.

Intended Audience

This document is for Digital Customer Services personnel only.

Tools and Equipment

The following table lists the tools and equipment you need to install the VS30U option:

Item	Part Number
Customer Services tool kit (United States)	29-26109-00
Customer Services tool kit (European)	29-26106-00
Antistatic kit	29-26246-00

Related Documents

The following documents can be ordered from Digital:

Document	Order Number
Microsystems Graphic Upgrade Installation Guide	EK-GPXUP-IN
BA430/BA440 Enclosure Maintenance Guide	EK-348AA-MG
KA660 CPU System Maintenance Guide	EK-398AA-MM
KA670 CPU System Maintenance Guide	EK-347AB-MG

Digital personnel may order the documents from:

Digital Equipment Corporation
444 Whitney Street
Northboro, MA 01532

Attn: Publishing and Circulation Services (NRO2-2)
Order Processing Section

Conventions

This document uses the following conventions:

Convention	Meaning
NOTE	Provides general information.
CAUTION	Provides information that prevents damage to equipment and software.
P/N	Part number.
Return	Key names appear in a box.
bold text	Bold text represents user input.

1

VS30U Graphic Upgrade

1.1 Planning the Upgrade

This section explains how to plan the upgrade. The information in this section includes the following:

- Software backup and operating system shutdown
- Guidelines for module placement
- Recommended module order
- Checking system limitations

1.1.1 Software Backup and Operating System Shutdown

It is the customer's responsibility to perform a software backup and to shut down the operating system software before you begin the upgrade.

1.1.2 Guidelines for Module Placement

The information in this section includes the following:

- Guidelines for placing modules in the backplane
- Bus grant continuity
- Power supply (H7847)

Bus Grant Continuity

Bus grant signals pass through each installed module through row A of each slot. Figure 1-1 shows the path of the bus grant signals in a BA430 enclosure.

NOTE

There are only seven Q-bus slots contained in the BA440 enclosure.

2 VS30U Graphic Upgrade

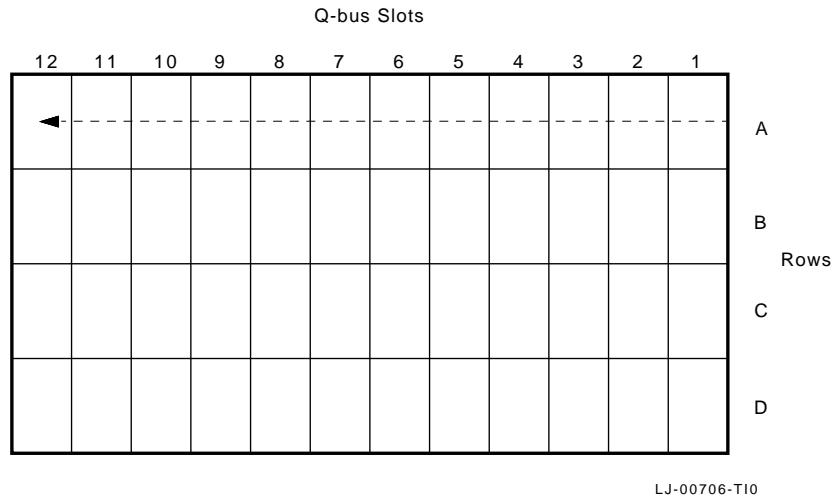

Figure 1–1 Bus Grant Continuity Path (BA430 Enclosure)

To ensure the continuity of the path, use grant continuity cards (M9047) in empty backplane slots. It is not necessary to install grant continuity cards in empty slots beyond the last module in the backplane.

Power Supply (H7847)

Refer to the *BA430/BA440 Enclosure Maintenance* manual for information about the H7847 power supply.

1.1.3 Recommended Module Order

The module order in the backplane depends on four factors:

1. The relative use of modules in the system
2. The expected performance of each module relative to other modules
3. The ability of a module to tolerate delays between bus requests and bus grants (delay tolerance)
4. The tendency of a module to prevent modules farther from the CPU from accessing the bus

To achieve maximum performance of the customer's system, place the modules in the backplane in the proper order. Refer to the following documentation for proper placement of the modules:

- *KA660 CPU System Maintenance Guide*
- *KA670 CPU System Maintenance Guide*

1.1.4 Checking System Limitations

To check system limitations, follow these procedures:

1. Make a copy of a configuration worksheet; copy either Figure 1–2 or Figure 1–3, depending on which configuration you are working on, and record all modules and mass storage devices on the configuration worksheets.

Use Table 1-2 in the *Microsystems Graphics Upgrade Installation Guide* to obtain the values for current, power, and I/O panel inserts for each module and device.

2. Add the columns on the worksheets and compare each column total with the *must not exceed* value listed beneath it. The total **must** be lower than this value.

If the values exceed those allowed, the customer must decide which of the modules or devices can be eliminated from the planned configuration. The system must fall within the allowed values.

After you have planned the upgrade and determined the locations of the modules, you are ready to perform the upgrade.

4 VS30U Graphic Upgrade

Figure 1–2 shows a blank configuration worksheet for a BA440 enclosure.

SLOT	MODULE	Current (Amps)				Power (Watts)	Bus Load	
		+5 Vdc	+12 Vdc	+3.3 Vdc	-12 Vdc		AC	DC
MEM 1								
MEM 2								
MEM 3								
MEM 4								
CPU	L4000 - BA	7.40	0.35	0.27	0.04	42.6	4.0	1.0
Q-bus 1								
Q-bus 2								
Q-bus 3								
Q-bus 4								
Q-bus 5								
Q-bus 6								
Q-bus 7								
H3604		1.7	0.5	0.0	0.25	17.5	—	—
MASS STORAGE:								
1 Tape/Disk							—	—
2 Disk								
3 Disk								
4 Disk								
Total these columns:								
Must not exceed:		60.0 A	22.0 A	15.0 A	3.0 A	584.0 W	31	20

Note: Total output power from +3.3 and +5 Vdc must not exceed 330 W

LJ-00707-T10

Figure 1–2 BA440 Configuration Worksheet

Figure 1–3 shows a blank configuration worksheet for a BA430 enclosure.

SLOT	MODULE	Current (Amps)				Power (Watts)	Bus Load	
		+5 Vdc	+12 Vdc	+3.3 Vdc	-12 Vdc		AC	DC
0	M9715	0.1	1.0			12.5		
CPU 1	M7626	4.8	0.55			30.6	3.5	1
Mem 2								
Mem 3								
Mem 4								
Mem 5								
Q/CD 6								
Q/CD 7								
Q/CD 8								
Q/CD 9								
Q/CD 10								
Q/CD 11								
Q/CD 12								
MASS STORAGE:								
1 Tape/Disk							—	—
2 Disk								
3 Disk								
4 Disk								
Total these columns:								
Must not exceed:		60.0 A	22.0 A	15.0 A	3.0 A	584.0 W	31	20

Note: Total output power from +3.3 Vdc and +5 Vdc must not exceed 330 W

LJ-00693-T10

Figure 1–3 BA430 Configuration Worksheet

1.2 Installing the VCB02 Module Set

The VCB02 module set requires a minimum firmware revision level to operate with the VAXserver 4000 model 300 system. If you are installing the VCB02 module set on a:

- VAXserver 4000 model 300 system, then go to Section 1.2.1
- System other than a VAXserver 4000 model 300 system, then go to Section 1.3

1.2.1 VAXserver 4000 Model 300 Firmware System Revision Verification.

To verify that the VAXserver 4000 model 300 system has the required minimum firmware revision level, type the following at the console prompt (>>>):

```
>>> SHOW VERSION 
```

The following is an example of what will be displayed on the screen:

```
KA670-A V3.7 VMB 2.12
```

If the screen displays V3.7 VMB 2.12 or greater, then ROM replacement is not necessary. Go to Section 1.3.

If the screen displays a version less than V3.7 VMB 2.12, then ROM replacement is required. Go to Section 1.2.2.

1.2.2 VAXserver 4000 Model 300 ROM System Replacement

The following procedure describes how to remove and install the two ROMs that are located on the KA670-BA CPU module.

Materials required

The following materials are required for the ROM replacement procedure:

- Customer Services tool kit
- Antistatic kit
- ROM kit (See Table 1–1.)

Table 1–1 ROM Kit Description

ROM Part Number	ROM Location	System	CPU Module	Module Number
23-234E9-00	E03 low byte	VAXserver 4000 model 300	KA670-BA	L4000-BA
23-235E9-00	E17 high byte	VAXserver 4000 model 300	KA670-BA	L4000-BA

CAUTION

Observe all electrostatic discharge (ESD) procedures before you remove any modules. It is mandatory to wear an ESD-approved ground strap and to place all modules in appropriate ESD containers, bags, or mats. This is in accordance with DEC Standard 067 (A-DS-EL00067-00-0), which provides the requirements for handling ESD devices.

Follow these procedures to remove and install the ROMs:

1. Unlock the front door and open both access doors together to reach the power switch on the power supply. Turn the power off.
2. Put on the grounded wrist strap and attach the alligator clip to the system chassis.
3. Note the position of the external cables connected to the H3604 console module. Label and disconnect the cables.
4. Open the H3604 console module. Note the position of the internal cables connected to the module. Carefully disconnect the internal cables.
5. Remove the KA670-BA CPU module from the system.

8 VS30U Graphic Upgrade

6. Remove the old ROMs from the sockets. Figure 1-4 shows the location of the ROMs.

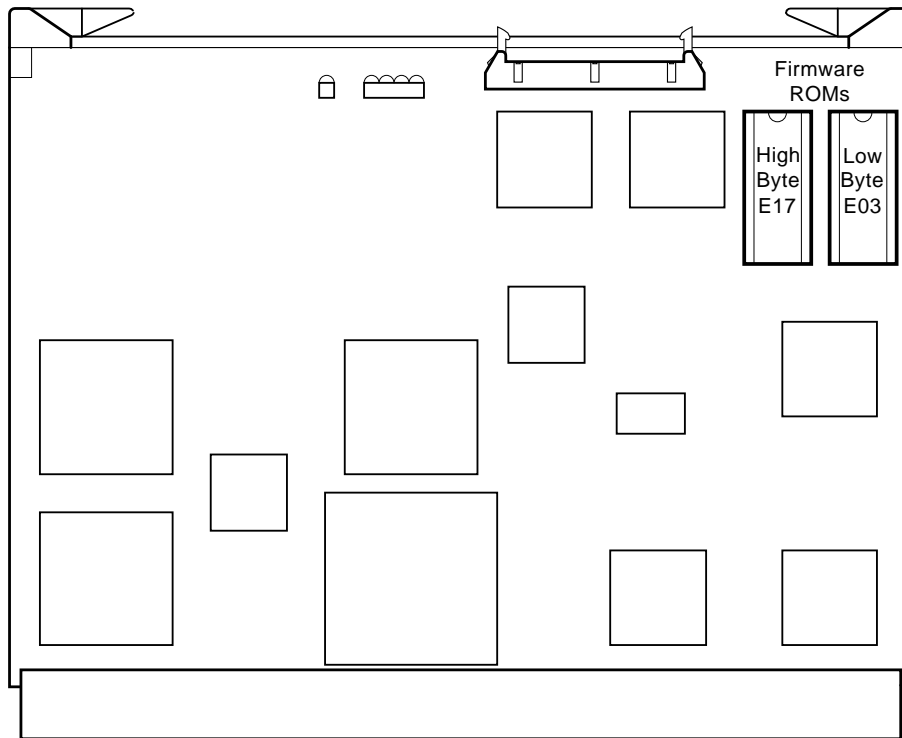

LJ-00708-T10

Figure 1-4 KA670 CPU Module - Component Side

7. Install ROM, P/N 23-235E9-00 (high byte), into location E17 on the KA670-BA CPU module (Figure 1-4).
8. Install the ROM, P/N 23-234E9-00 (low byte), into location E03 on the KA670-BA CPU module (Figure 1-4).

9. Check the following to ensure that the ROMs are installed properly:
 - The ROMs' alignment notches should be in the correct position.
 - There should be no bent pins.
10. Reinstall the KA670-BA CPU module and reconnect the internal cables that were disconnected in step 4.
11. Reconnect the external cables to the H3604 console module that was disconnected in step 3.
12. Perform the system power-up self-test. If failure occurs, recheck the ROM installation.

1.3 Relocating Modules

Check the recommended module order recorded on the BA430 or BA440 configuration worksheet to determine in which three slots the VCB02 modules should be installed. (Refer to Figure 1–2 or Figure 1–3 for the blank configuration worksheets.) If you need to relocate modules in the backplane, use the following procedures to install and remove modules with covers:

CAUTION

Use the antistatic kit when working with modules.

1. Unlock the front door and open both access doors together to reach the power switch on the power supply. Turn the power off.
2. Put on the grounded wrist strap and attach the alligator clip to the system chassis.
3. Note the orientation and location of the cables connected to the modules. Label and disconnect the cables.
4. Remove all necessary module handles and covers by releasing the quarter-turn captive screws that hold the handle to the card cage (Figure 1–5).

10 VS30U Graphic Upgrade

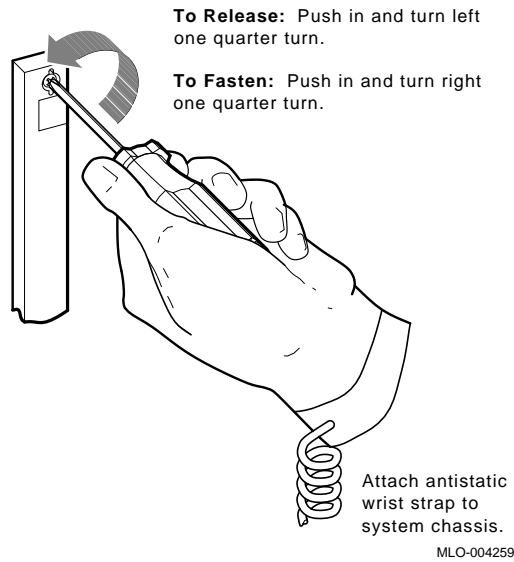

Figure 1-5 Releasing Quarter-Turn Captive Screws

5. Pull the handle out at the top and bottom.
6. Note the orientation of any internal cables connected to the module. Some connectors are not keyed. Carefully disconnect the internal cables.
7. Gently pull the release handles at the top and bottom of the module toward you, and slide the module out of the card cage (Figure 1-6).

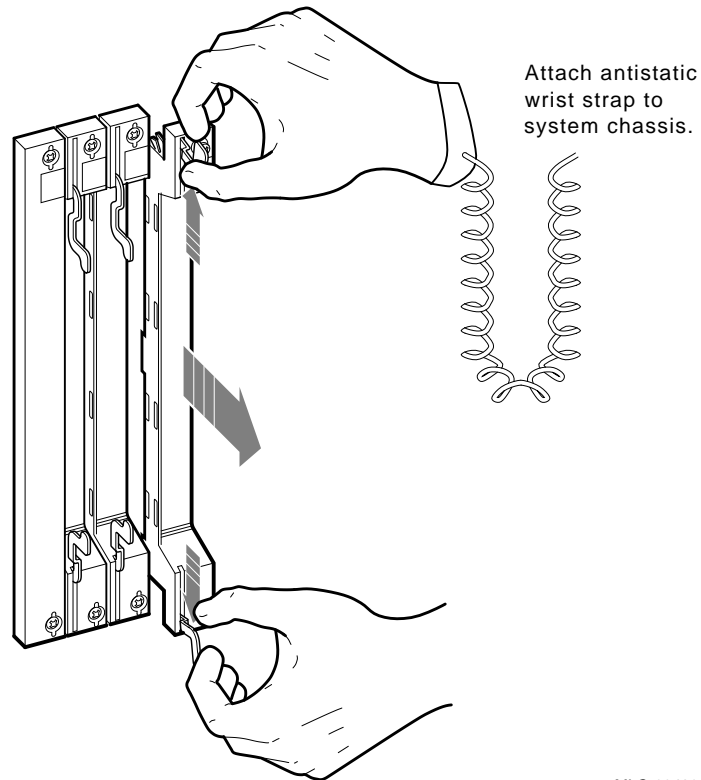

Figure 1–6 Removing a Module

Inspecting the EMI and EOS Clips

To comply with regulations on electromagnetic interference (EMI), bulkhead handles, blank covers, and gap fillers have transient protection EMI and electrical overstress (EOS) clips. These clips are grounded through the handle. Perform the following procedure to ensure proper grounding:

1. Check the EMI and EOS clips on the blank dual cover for residue or corrosion (Figure 1–7). Remove any residue or corrosion with alcohol.

12 VS30U Graphic Upgrade

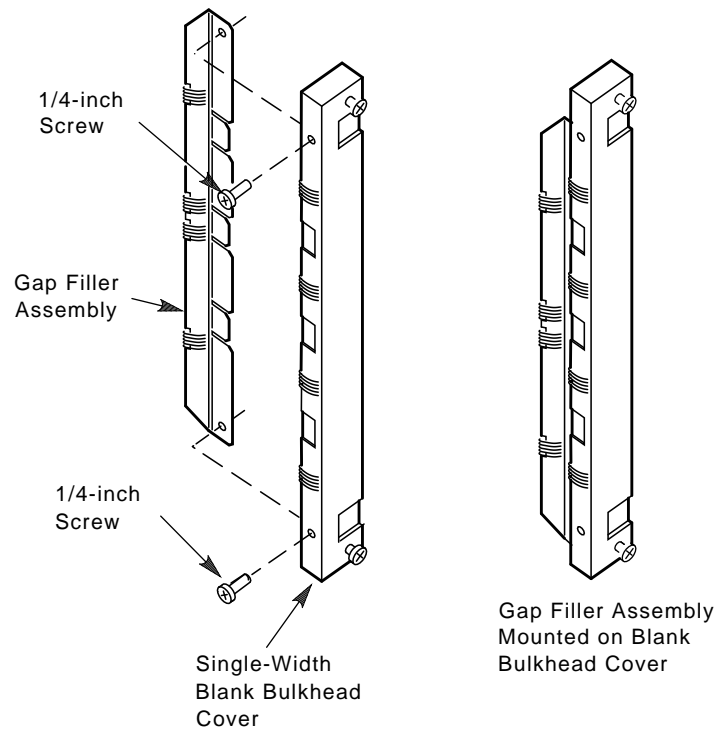

MA-X0019-88

Figure 1-7 EMI and EOS Clips

2. Make sure the EMI and EOS clips are arched. When you press them slightly, they should return to their original shape.
3. If any clip is missing or broken, replace it. The following table lists the part numbers:

Clip	Part Number
EMI clip	12-26340-01
EOS clip	12-26922-01

1.4 Installing a VS30U Graphics Kit

To install a VS30U graphics kit you must do the following:

- Configure the VCB02 module set.
- Install the three graphics modules, bulkhead covers, and BC13B-25 monitor cable.
- Install the monitor, keyboard, and mouse.

The following subsections describe these procedures in detail.

1.4.1 Configuring the VCB02 Module Set

The correct control status register (CSR) addresses must be set on the graphics modules for the graphics subsystem to be recognized and located by the system. The VCB02 base module contains a 4-switch dual in-line package (DIP) switchpack E4 that controls the CSR address. (Refer to the *Microsystems Graphics Upgrade Installation Guide*, Figure 2-1, for the location of the DIP switchpack.) The module is set at octal address 17777400. The switch settings for the address are given in the following table:

Table 1–2 CSR Settings for the VCB02 (Switchpack E4)

Switch	Setting
S1	0 (on)
S2	0 (on)
S3	0 (on)
S4	Not used

The interrupt vector for the VCB02 base module is set under program control. You do not have to set switches for the second module (VCB02 4-plane module) or for the third module.

NOTE

Two 4-plane modules create the 8-plane system.

Figure 1-8 shows the cabling between graphics modules and the I/O distribution insert.

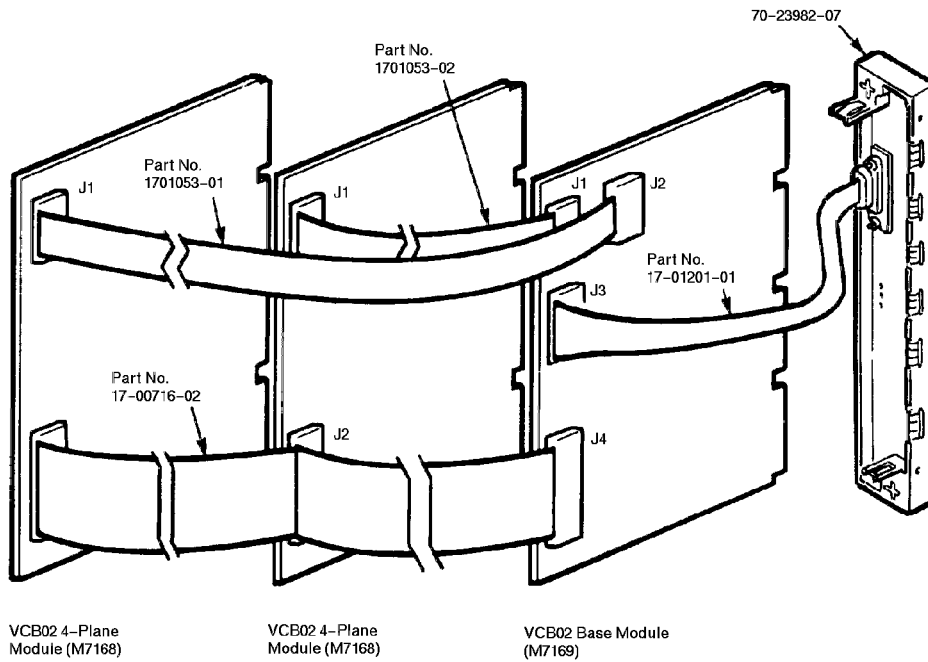

LJ-00044-SCAN

Figure 1-8 VCB02 Module Cabling

1.4.2 Installing Modules

To install the modules, use the following procedures:

1. Install the VCB02 base module (M7169, minimum CS revision D2) into the slot to the far right of the selected location. Be sure to position the component side of the module towards the right.
2. Install the VCB02 4-plane modules (M7168) into the next two left-hand slots adjacent to the base module. Be sure to position the component side of the module towards the base module.
3. Connect the three cables in the kit as shown in Figure 1–8.
4. Connect the cable on the dual-width bulkhead cover to the VCB02 base module (J3).
5. Install the dual-width bulkhead cover over the VCB02 base module and the first VCB02 4-plane module.
6. Install a blank single-width bulkhead cover over the second VCB02 4-plane module.
7. Apply the two labels in the kit to the bulkhead covers.
8. Connect the BC13B-25 monitor cable to the dual-width bulkhead cover.
9. Close the system cabinet and perform a power-up self-test.

1.5 Installing the Monitor, Keyboard, and Mouse

Complete the following procedure to install the monitor, keyboard, and mouse:

1. Shut down the system power.
2. Connect the BC13B-25 monitor cable to the VR299 monitor (Figure 1–9).

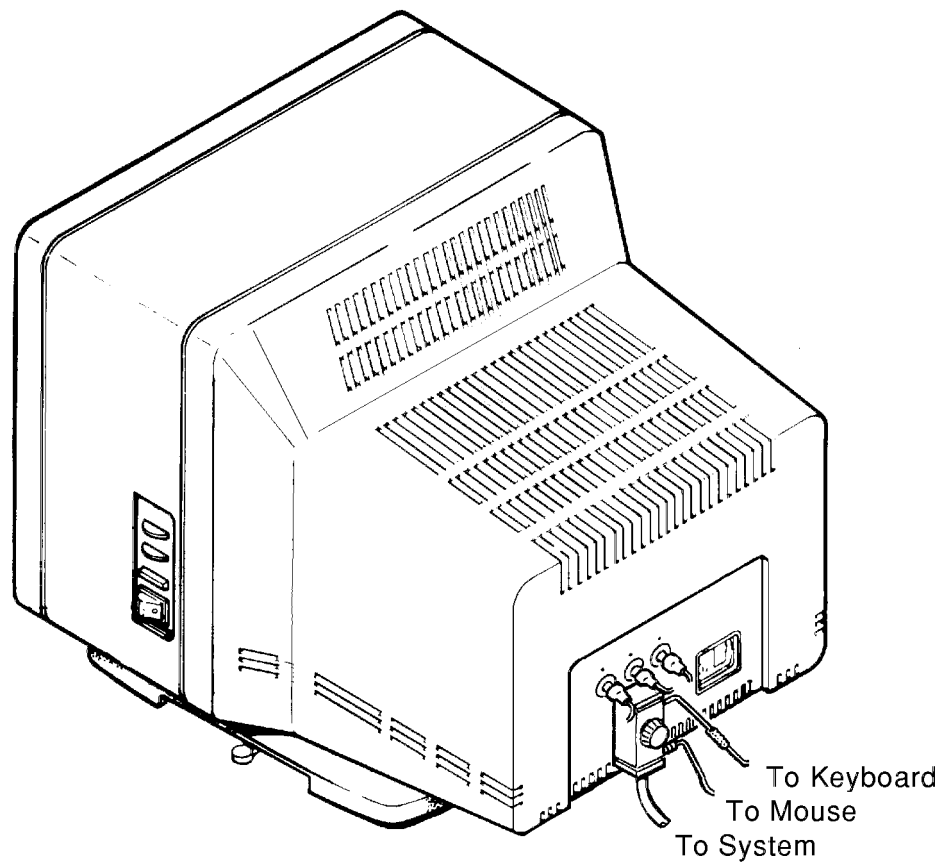

LJ-00043-SCAN

Figure 1-9 Connecting the Cables to the VR299 Monitor

3. Connect the mouse and the keyboard to the BC13B-25 cable.
4. Turn on the power to the system and the VR299 monitor.